



Italian Openings & Automation

SINCE 1954

UMO

UNDERGROUND MECHANICAL OPERATOR

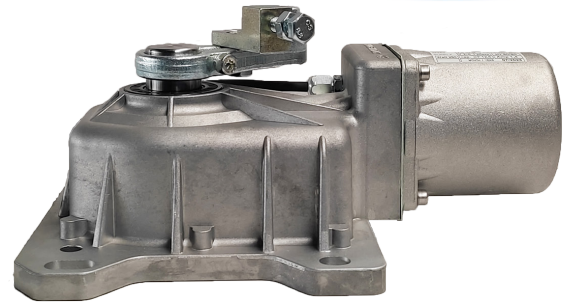
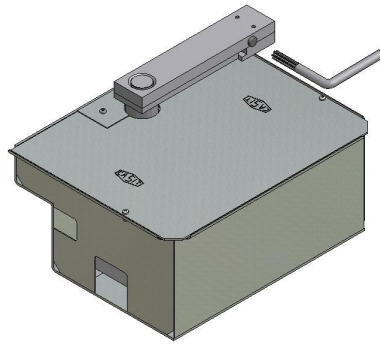

ISO 9001: 2015

- OPERATORE ELETTRMECCANICO IRREVERSIBILE INTERRATO PER CANCELLI A BATTENTE . SICURO ROBUSTO. EQUIPAGGIATO DI SBLOCCO MANUALE .RIDUTTORE IN PRESSOFUSIONE DI ALLUMINIO, INGRANAGGI - IN GHISA E IN BRONZO. LUBRIFICAZIONE A GRASSO.**
- ELECTROMECHANICAL UNDERGROUND OPERATOR SELFLOCKING FOR SWING GATES, SAFE ROBUST, RELIABLE AND NOISELESS. EQUIPPED OF MANUAL RELEASE. GEARBOX IN ALUMINIUM DIECASTING, BRONZE GEAR. LUBRICATED WITH GREASE.**
- OPÉRATEUR ÉLECTROMÉCANIQUE AUTOBLOQUANT ENCASTRÉ POUR PORTAILS BATTANT. SÛR SOLIDE ,FIABLE ET SILENCIEUX. ÉQUIPÉ DE DÉVERROUILLAGE. REDUCTEUR EN DIE-CAST ALUMINIUM, ENGRANAGE ACIER EN BRONZE . LUBRIFICATION GRAISSE .**
- OPERADOR ELECTROMECÁNICO IRREVERSIBLE EMPOTRADO PARA PUERTAS BATIENTES. SEGURO, RESISTENTE, FIABLE Y SILENCIOSO. EQUIPADO CON DESBLOQUEO. REDUCTOR DE ALUMINIO FUNDIDO, ENGRANAJE DE ACERO Y BRONCEADO. LUBRICADO CON GRASA.**



CARATTERISTICHE TECNICHE / TECHNICALS DATA / CARACTERISTIQUES TECHNIQUES / CARACTERISTICAS TECNICAS

Alimentazione monofase	Power supply monophase	Alimentation	alimentación	monofase - monophase - monophasè 230 Vac 60/50Hz
Corrente	Current	Courant	corriente	1,4 A
Potenza assorbita	Absorbed power	Puissance absorbée	potencia absorbida	280 W
Coppia	Torque	Couple	par	280 Nm
Condensatore	Condenser	Condensateur	condensador	12,5 Mf
Rapporto di riduzione	Reduction ratio	Rapport de réduction	relación de reducción	1:935
Giri/minuto albero motoriduttore	Speed RPM	Vitesse axe moteur	velocidad del eje del motor	1,5 /min
Temperature d'esercizio	Working temperature	Température de service	temperatura de funcionamiento	- 20C / 70+C
Grado di protezione	Protection level	Indice de protection	índice de protección	IP 67
Peso operatore	Operator weight	Poid operateur	peso del operado	10 kg

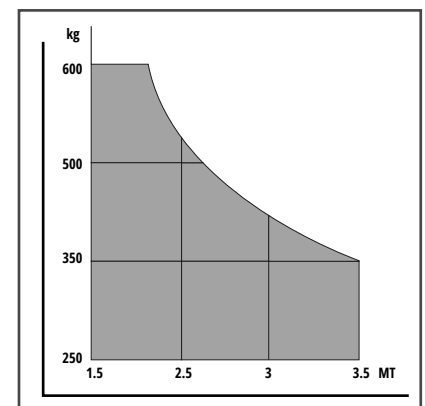

Anta - Leaf - Battant - Hoja - Blatt

Intermittenza di lavoro S3 40%. Per uso intensivo i valori dei limiti d'impiego vanno ridotti del 30% - S3 40% - Fonctionement S3 40% - uso S3 40%

Tempo di apertura 90°	Opening time 90°	Temps d'ouverture 90°	tiempo de apertura de 90°	16 sec
-----------------------	------------------	-----------------------	---------------------------	--------

AF0051/ML 09/23

Strada Pietra ALTA CASELETTE (TO) Italy - Tel. +39 (0)119 688 230 - +39 (0) 119 688 170 - Fax +39 011 9688363 - info@casit.it - www.casit-italy.com

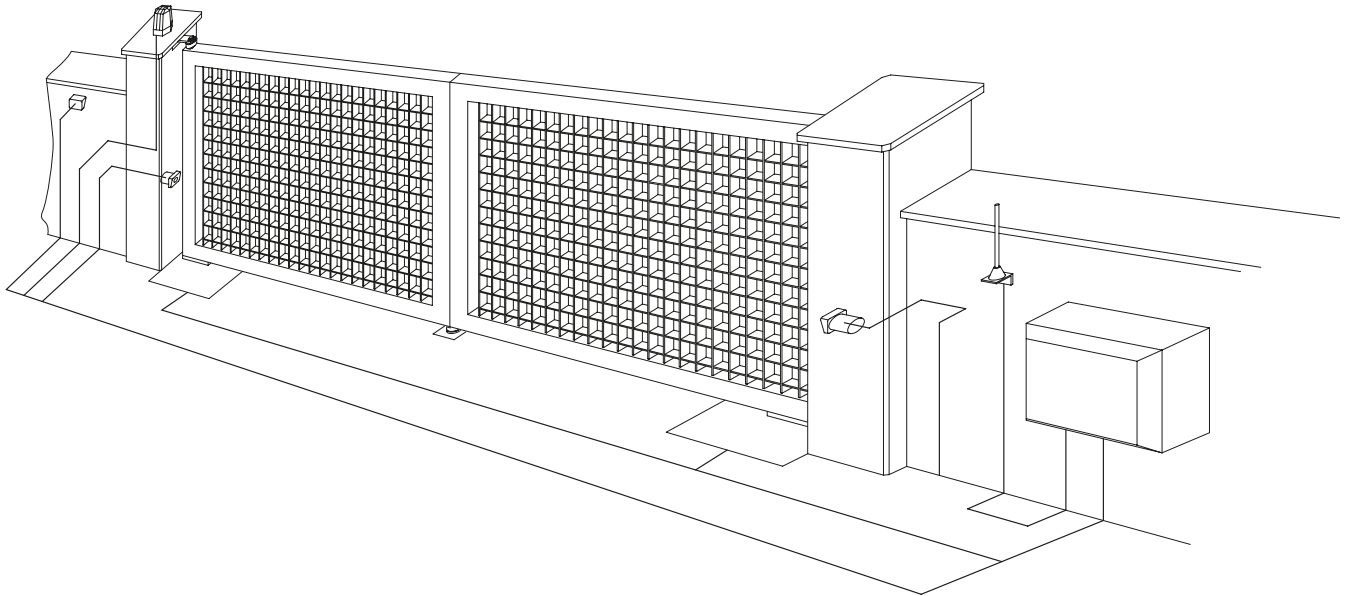

Dimensioni d'ingombro – Dimensions – Dimensions d'encombrement

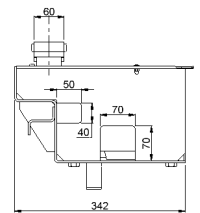
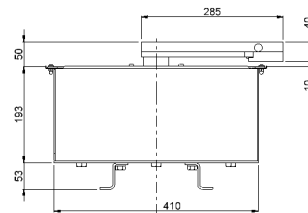
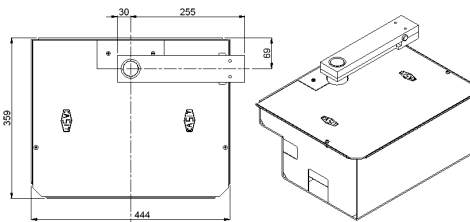
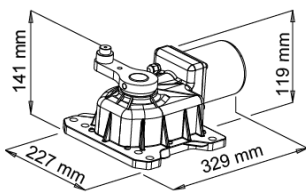

Larghezza anta – Door width – Largeur vantail

Max 3,5 mt

Peso anta – Door weight – Poids vantail

Max 600 kg



Attenzione: La forma, l'altezza del cancello (es: cieco) e le condizioni climatiche (es. vento forte) possono ridurre anche notevolmente i valori dei limiti d'impiego.

Warning: The form, the height of the gate (ex: blind) and the climatic conditions (ex. strong wind) they can also reduce the values of the limits of employment.

Attention: La forme, l'hauteur du portail (ex: aveugle) et les conditions climatiques (ex. vent fort) peut réduire les valeurs des limites d'emploi.

Advertencia: El diseño, la altura de la puerta (por ejemplo, persiana) y las condiciones climáticas (por ejemplo, viento fuerte) también pueden reducir los valores de los límites de funcionamiento

NOTE

🇮🇹 Installare i dispositivi previsti dalle norme vigenti. I prodotti sono corredati di libretto avvertenze e istruzioni montaggio. I dati sono indicativi e possono essere variati senza preavviso.

🇬🇧 Install the safety devices following the standard. The products are accompanied by the advertisement and installation maintenance hand-book. This data are indicative and can be changed without notice.

🇫🇷 Installer les dispositifs de sécurité prévus par le normes. Les produits sont accompagnés d'un carnet d'avertissement et des instruction de montage. Les données techniques sont indicatives et peu vent être modifiées sans aucun préavis.

🇪🇸 Instale los dispositivos previstos por las normas vigentes. Los productos tienen incluido folleto explicativo e instrucción de montaje. Las informaciones pueden variar sin aviso.