



MR300/SEZ 63

CASIT®

dal 1950 Qualità e Sicurezza



AUTOMATISMI PER PORTONI INDUSTRIALI SEZIONALI-SCORREVOLI-A LIBRO E ALTRI



OPERATORS FOR INDUSTRIAL GATES SECTIONAL-SLIDING-FOLDING AND OTHERS



AUTOMATISMES POUR PORTAILS INDUSTRIELS SECTIONNELS-COULISSANTS-ACCORDEON ET AUTRES



AUTOMATIZACIONES PARA PORTONES INDUSTRIALES SECCIONALES-CORREDIZO-REPLEGABLE-OTROS



AUTOMATISMEN FÜR INDUSTRIELLE TORE SEKTIONALE-SCHIEBE-FALTTÖRE UND WEITERE



Costruito in due versioni:
 Monofase (A) e Trifase (B), con fine corsa rotativo e svincolo manuale.
COMPATTO e facile da installare.
VERSATILITÀ di utilizzo.
ADATTO per portoni industriali di ogni tipo.
COMANDO MANUALE d'emergenza a leva rapida.
RIDUTTORE irreversibile in alluminio pressofuso.
MOTORE ventilato e con protettore termico.
VITE in acciaio e ingranaggio in bronzo.



Manufactured in two models:
 Singlephase (A) and threephase (B) with rotative limit-switch
 and manual device.
COMPACT and easy to install.
MANY possibility of utilization.
GOOD for all type of industrial gate.
MANUAL DEVICE by fast lever.
NOT-REVERSIBLE aluminium reducer.
FAN COOLED motor with thermal protection.
STEEL-SCREW and bronze-gear.



Fabriqu  en 2 versions:
 Monophas  (A) et Triphas  (B), avec fin de course rotatif
 et d pannage manuel.
COMPACT et facile   installer.
PLUSIEURS possibilit s d'utilisation.
ADAPT  pour tout type de portail industriel.
DEPANNAGE MANUEL par levier rapide.
REDUCTEUR irreversible en aluminium.
MOTEUR ventil  avec protection thermique.
VIS en acier et engranage en bronze.



Fabricado en dos tipos:
 Monof sico (A) o trif sico (B), con final de carrera rotativo
 y mando manual de emergencia.
COMPACTO y f cil de instalar.
VERSATILIDAD de utilizaci n.
ADECUADO para portones industriales de cualquier tipo.
MANDO MANUAL de emergencia de palanca r pida.
REDUCTOR IRREVERSIBLE de aluminio fundido a presi n.
MOTOR VENTILADO y con protector t rmico.
TORNILLO de acero y engranaje de bronce.



In 2 Ausf hrungen verf gbar:
 Einphasig (A) und Dreiphasig (B), mit Drehenschalter und Handbefreiung.
KOMPAKT und einfach zu installieren.
GEBRAUCHSGEWANDTHEIT.
GEEIGNET f r alle Sorte von industriellen Toren.
NOTHANDSTEUERUNG mit schnellem Hebel.
IRREVERSIBELER REDUKTOR in Druckgu aluminium.
GEL FTETER MOTOR mit W rmeschutzvorrichtung.
STAHLSCHRAUBE und Getriebe aus Bronze.

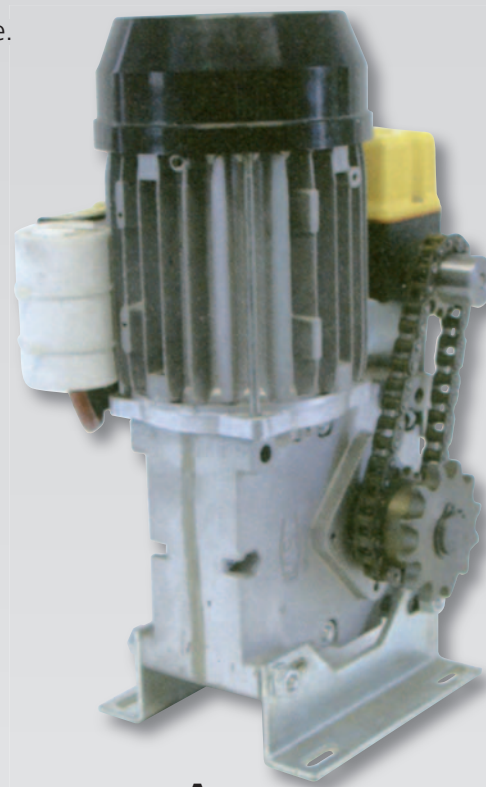

A

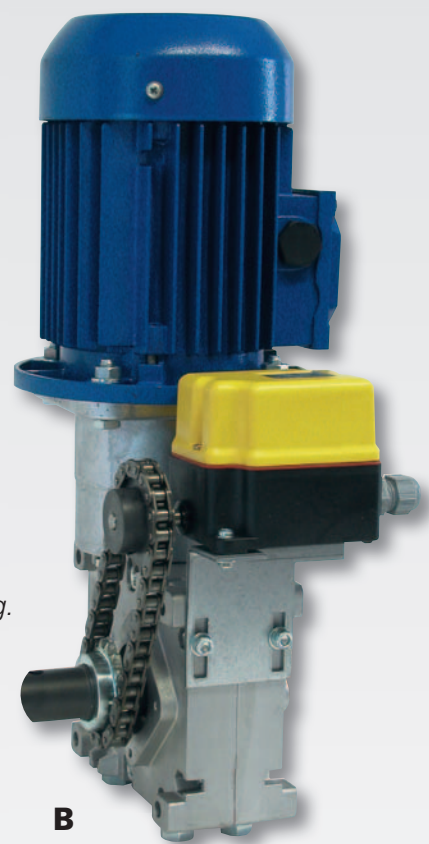

B

ESEMPI DI APPLICAZIONI - EXAMPLE OF APPLICATION - EXEMPLES D'APPLICATION EJEMPLOS DE APLICACION - BEISPIELE VON ANWENDUNGEN

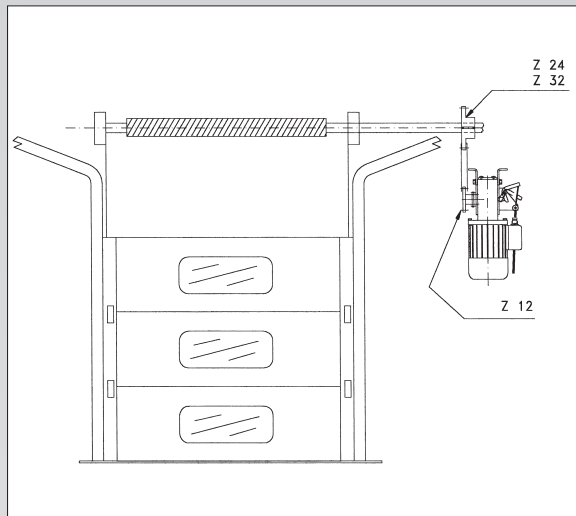

SEZIONALE - SECTIONAL - SECTIONNELLE - SECCIONAL - SEKTIONALTOR

	Monofase - Singlephase Monophasé - Monofásico Einphasen (A)			Trifase - Threephase Triphasé - Trifásico Dreiphasen (B)		
Pignone motore - Pinion motor - Pignon moteur - Piñon motor - Ritzel Motor	Z12					
Pignone condotto - Pinion driven - Pignon conduit - Piñon conducto - Ritzel geschlepptes	Z24	Z32		Z24	Z32	
Coppia - Torque - Couple - Par - Drehmoment Nm	25	50	67	40	80	107
Velocità - Speed - Vitesse - Velocidad - Geschwindigkeit rpm	40	21	16	40	21	16

SCORREVOLE - SLIDING - COULISSANT - CORREDERA - SCHIEBETOR

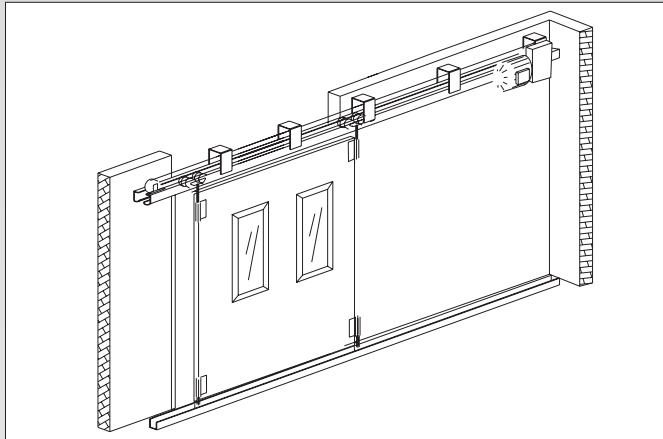

A LIBRO - FOLDING - ACCORDEON - PLEGABLE - FALTOR

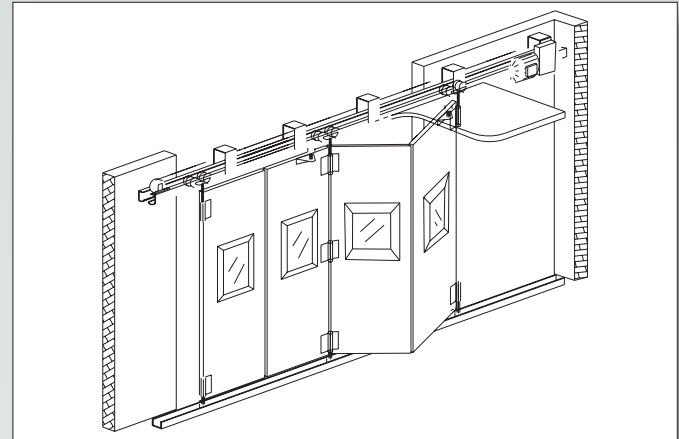

	Monofase - Singlephase Monophasé - Monofásico - Einphasen (A)	Trifase - Threephase Triphasé - Trifásico - Dreiphasen (B)
Peso porta - Door's weight - Poids du portail - Peso puerta - Gewicht des Tors	1500 kg max	2000 kg max
Velocità - Speed - Vitesse - Velocidad - Geschwindigkeit	8 m/1'	
Campo utile finecorsa rotativo - Range of the rotative limit-switch - Utilisation fin de course rotatif - Campo util final de carrera rotativo - Nützliche Reichweite des Drehenschalters	9 m	

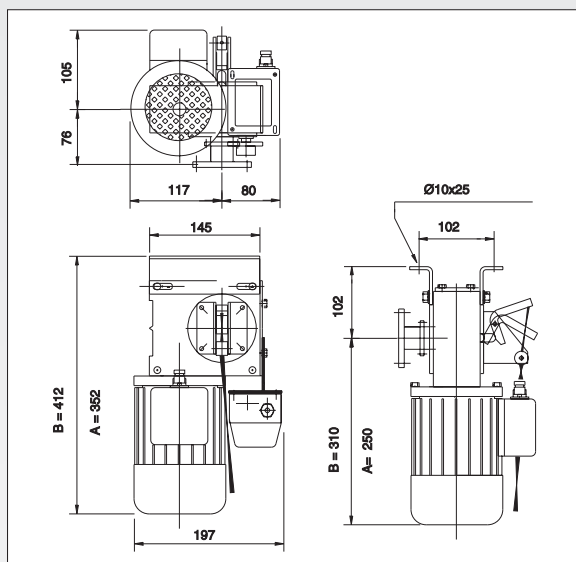

Maniglia sblocco con chiave
Manual release with key
Poignée déblocage avec clé
Maneta desbloqueo con llave
Handsteuerung mit Schlüssel

CARATTERISTICHE TECNICHE

TECHNICALS DATA / CARACTERISTIQUES TECHNIQUES / CARACTERISTICAS TECNICAS / TECHNISCHE DATEN

					MR33/SEZ 63 MD	MR33/SEZ 63 TD	MR33/SEZ 71 MD	MR33/SEZ 71 TD
Alimentazione	Power supply	Alimentation	Alimentación	Spannungsversorgung	230VAC 50/60Hz 1 phase IP45	230/400VAC 50/60Hz 3 phase IP45	230VAC 50/60Hz 1 phase IP45	230/400VAC 50/60Hz 3 phase IP45
Condensatore	Capacitor	Condensateur	Condensador	Motorkondensator	20 Mf	—	25 Mf	—
Potenza	Motor power	Puissance moteur	Potencia del motor	Motorleistung	350 watt	370 watt	370 watt	400 watt
Assorbimento	Absorption	Consommation à vide	Absorbimiento	Leistungsaufnahme	2,5 A	1,9/1,1 A	3,2 A	1,8/1,1 A
Temperatura di esercizio	Working temperature	Température de fonctionnement	Temperatura de trabajo	Betriebstemperatur	-20 +70 C°			
Funzionamento	Operation	Fonctionnement	Funcionamiento	Betrieb	40%	80%	40%	80%
Giri	Revs speed	Vitesse de rotation	Velocidad	Drehzahl Elektromotor	40 RPM			
Finecorsa	Limit switches	Fin de course	Final de carrera	Öffnung Endschalter	1 Elettrico rotativo - Electric rotative - Electrique rotatif Electrico rotativo - Elektrick Drehendschalters			
Coppia	Torque	Couple	Par	Drehmoment	25 Nm		35 Nm	40 Nm
Campo lavoro finecorsa	Limitswitches capacity	Limite d'action des fins de course	Maxima capacidad final de carrera	Kapazität des Endschalters	50 giri albero - 50 rounds axis - 50 tours arbre creux 50 vuelta eje - 50 Touren Triebwelle			
Peso	Weight	Poids	Peso	Gewicht	10,5 kg		12,5 kg	

Porta - Door - Porte - Puerta - Tore										
A - Diametro tamburo - Diam. ring - Diam. tambour - Diam. tamburo - Durchmesser der Trommel mm	140	153	169	185	210					
B - Pignone montato su albero - Type of the gear to install on the axis - Pignon a monter sur l'axe - Pinion de l'axe - Ritzel, auf Welle eingebaut	Z24	Z32	Z24	Z32	Z24	Z32	Z24	Z32	Z24	Z32
C - Forza di sollevamento sulla fune - Power/lift on the cables - Force de levage des cables - fuerza de tiro sur cable - Hebestärke der Kabel Kg.	68	91	62	83	56	75	51	69	45	60
Velocità salita/discesa - Operation speed up/down - Vitesse montée/descente - Velocidad/apertura (arriba) y cierre (abajo) - Geschwindigkeit Aufstieg/Abstieg m/1'	8,8	6,6	9,6	7,2	10,6	8	11,6	8,7	13,2	9,9
Montaggio consigliato - Installation's choice - Option de montage - Montaje aconsejado - Empfohlene Installation	•	•	•	•	•	•	•	•	•	•

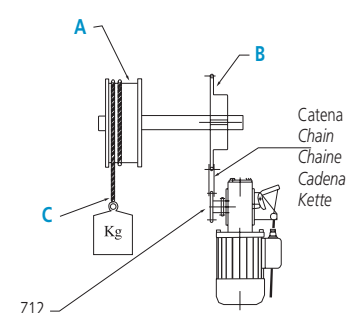

Catena
Chain
Chaîne
Cadena
Kette

N.B: Installare i dispositivi previsti dalle norme vigenti / To install the safety devices following the standard / Installer les dispositifs de sécurité prévus par les normes / Instale los dispositivos previstos por las normas vigentes / Während der Installation immer die geltenden Regel achten und die Schutzvorrichtung benutzen.

I prodotti sono corredati di libretto Avvertenze UNAC e istruzioni montaggio. I dati sono indicativi e possono essere variati senza preavviso. - The products are accompanied by the UNAC-advertisement and installation - maintenance Hand-book. This datas is indicative and can be changed without notice. - Les produits sont accompagnés d'un carnet d'Advertisements-UNAC et des instruction de montage. Les données techniques sont indicatives et peuvent être modifiées sans aucun préavis. - Los productos tienen incluido libretto Avvertenze UNAC y instrucción de montaje. Las informaciones pueden variar sin aviso. - Die Produkte sind mit dem handbuch mit den anweisungen UNAC und den montageanweisungen versehen. - Die technischen Daten haben rein orientativen Charakter und bedürfen bei Änderungen keinen Benachrichtigung.

AF0023/ML

I/08

CASIT®

Via Pietra Alta, 1 - 10040 CASELETTE (TO), Italy
Tel. +39 011 968 82 30 - 968 81 70 - 968 89 30
Fax +39 011 968 83 63
E-mail: info@casit.it - www.casit.it



ASSOCIATO:



UNIONE NAZIONALE COSTRUTTORI
DI AUTOMATISMI PER CANCELLI,
PORTE, SERRANDE E AFFINI