



Italian Openings & Automation

SINCE 1954

Operators for swing gates

TORINO 06



Operatore elettromeccanico per cancelli a battente a 1 o 2 ante fino a 5 mt. ciascuna. Struttura in pressofusione di alluminio, inox, bronzo e acciaio di qualità. Lubrificazione a grasso fluido, verniciatura a polvere di poliester, movimento con vite senza fine autolubrificata per garantire una lunga vita operativa.

Electromechanical operator for folding gates 1 or 2 wings up to 5 mt. each. Diecasting structure made of quality aluminum, stainless steel, bronze and steel. Fluid-grease lubrication system, polyester powder-paint, self-lubricating work screw to ensure a long-lasting working life

Operateur electromecanique pour portails à 1 ou 2 vantaux jusqu'à 5 mt. chacun. Structure en aluminium moulée sous pression des matériaux nobles, acier inox, bronze. Peinture en poudre polyester, un mécanisme silencieux lubrifié en permanence garantissent une longue qualité opérationnelle

Actuador lineal electromecánico para puertas batientes 1 o 2 hojas hasta 5 mt. cada una. Estructura de vaciado a presión de aluminio, inox, bronce y acero de calidad. La lubricación con grasa fluida, el barnizado con polvo poliéster, el movimiento con tornillos sin terminales autolubricados garantizan una larga vida operativa

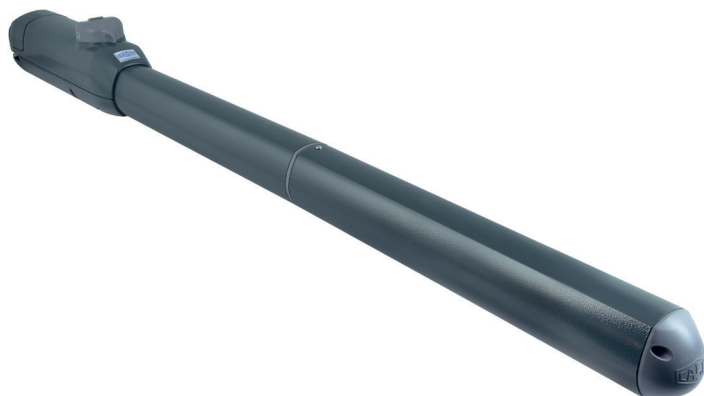

ISO 9001:2008



Made in Italy

TECHNICAL DATA

	TORINO 06/R (KAM001A00)	TORINO 06/IL (KAM002A02)	TORINO 06/IV (KAM002A01)
	Reversibile / Reversible	Irrev. con sblocco / Irrev. with release	Irrev. con sblocco / Irrev. with release
Alimentazione / Power supply / Alimentation	230 Vac 50 / 60 HZ		
Assorbimento / Current / Consommation à vide	1 A		1,2 A
Potenza assorbita / Absorbed power / Puissance moteur	200 W		300 W
Condensatore / Condenser / Condensateur	6,3 mF		4 mF
Protezione / Protection IP / Protection IP	44		
Velocità / Speed / Vitesse	16,2 mm/s	10,7 mm/s	16,6 mm/s
Corsa / Stroke / Course	415 mm		
Spinta max. / Max. thrust / Poussee max.	3000 N		
Temp. esercizio / Working temp. / Temp. de fonctionnement	Min - 20° / Max + 70° C		
Termoprotezione / Thermal protection / Protection thermique	135° C		
Peso motore / Motor weight / Poids moteur	9 kg		
Fincorsa eletromecc. di apertura / Limit switch on opening / Fin de course d'ouverture électromécanique	Yes		
Fincorsa eletromecc. di chiusura / Limit switch on closing / Fin de course de fermeture électromécanique	Yes		
Sblocco a chiave sull'operatore / Release on the operator / Opérateur déverrouillage à clé	Yes		
Sblocco a chiave lato esterno / Outside handle release / Déverrouillage à clé externe	Yes		
Funzionamento / Operation / Opération	60%		50%

LIMIT OF USE

Lunghezza max. anta / Max. wing length	Peso max. anta / Max. wing weight
2,00 mt.	600 kg
2,50 mt.	500 kg
3,00 mt.	400 kg
3,50 mt.	300 kg
4,00 mt.	250 kg
4,50 mt.	250 kg
5,00 mt.	200 kg

DIMENSIONS

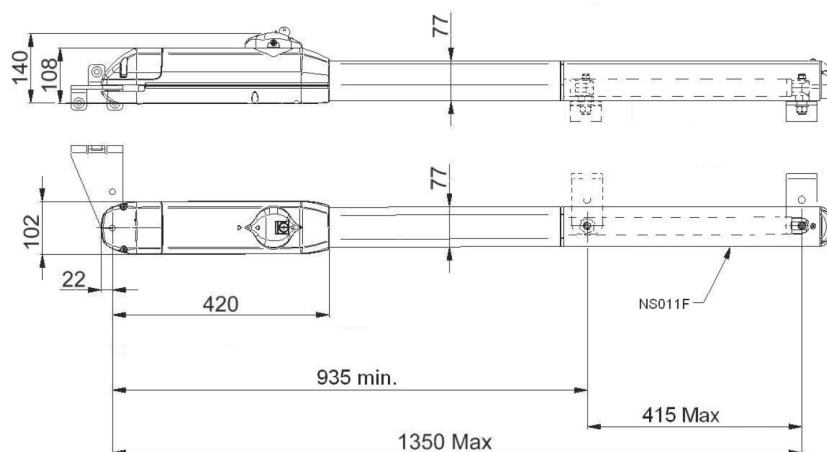

STANDARD LAYOUT

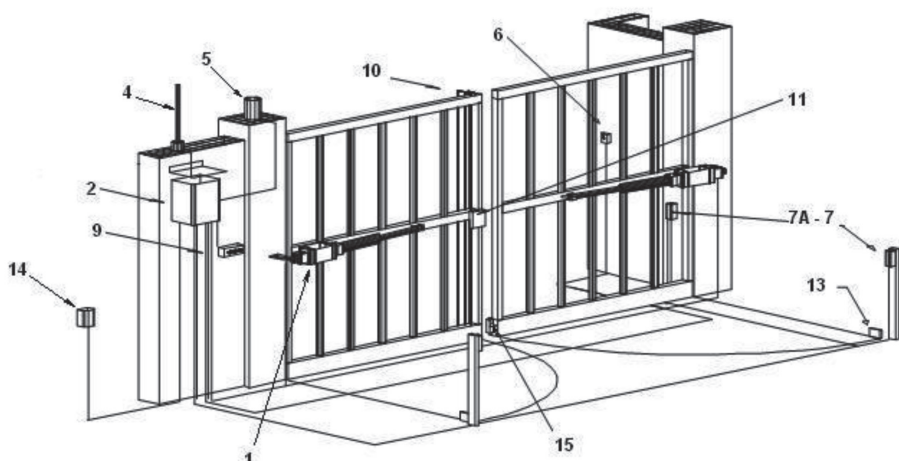

1	Operatore / Operator	3x1,5
1	Finecorsa elettrici / Limit switches	4x1
2	Quadro comando / Control box	
4	Antenna / Aerial	2
5	Lampeggiatore / Blinking light	2x1
6	Selettore a chiave / Key switch	2x1
7	Fotocellula interna / Photocell internal	4x1
7A	Fotocellula esterna / Photocell external	4x1
9	Pulsantiera / Push switch	4x0,5
10	Costa sensibile / Safety edge	2x0,5
11	Elettrosaldatura / Electrolock	2x0,5
13	Arresti meccanici / Mechanical stops	
14	Interruttore generale / Main switch	3x1,5
15	Piastra di fissaggio / Mechanical latch	

ACCESSORIES INCLUDED



Piastra di fissaggio / Fixing plate



ATTENTION

■ Installare i dispositivi previsti dalle norme vigenti. I prodotti sono corredati di libretto avvertenze e istruzioni montaggio. I dati sono indicativi e possono essere variati senza preavviso.

■ Install the safety devices following the standard. The products are accompanied by the advertisement and installation maintenance hand-book. This data are indicative and can be changed without notice.

■ Installer les dispositifs de sécurité prévus par le normes. Les produits sont accompagnés d'un carnet d'avertissement et des instruction de montage. Les données techniques sont indicatives et peuvent être modifiées sans aucun préavis.

■ Instale los dispositivos previstos por las normas vigentes. Los productos tienen incluido folleto explicativo e instrucción de montaje. Las informaciones pueden variar sin aviso.

AF0041/ML - III/17